



深圳市威利特自动化设备有限公司

Shenzhen Vility Automation Machinery Co., Ltd

公司地址：深圳市宝安区沙井镇新桥芙蓉工业区芙蓉七路 2 号第二栋。

Address: Furong Industrial Zone, Shajing, Baoan District, Shenzhen

电话： 0755-27255688 传真： 0755-88213652

Tel: 0755-27255688 Fax: 0755-88213652

售后专线： 13392878825 0755-33157272

After-sales line: 13392878825 0755-33157272

苏州办事处：江苏省昆山市城北西路 2258 号

Suzhou Office: No. 2258 West Chengbei Road, Kunshan City, Jiangsu Province

电话： 0755-27255688 传真： 0755-88213652

Tel: 0755-27255688 Fax: 0755-88213652

网址： www.szvility.com Website: www.szvility.com

威利特 CCD 对位卷料丝印机安装手册**CCD Alignment Roll to Roll Screen Printing Machine Installation Manual**

一：确保输入 AC 电源为 415V 50HZ。

1: Make sure the input AC power is 415V 50HZ.

二：确保外接气源压强在 0.5~0.8MPa 之间。

2: Make sure the pressure of external air source is between 0.5~0.8MPa.

三：确保平台丝杆有黄油润滑，转动流畅。

3: Make sure the platform screw has grease lubrication and smooth rotation.

四：确保吸风台面网纱脏了及时更换，拉料辊筒干净无油墨。

4: Ensure that the dirty mesh yarn on the suction table is replaced in time, and the pulling roller is clean and free of ink.

五：空压机最好带有气体干燥，若空压机输出气体没有带干燥，每星期排水一次。

5: The air compressor had better be dried with gas. If the output gas of the air compressor is not dried, it should be drained once a week.

六：检查脚杯是否放稳，平衡。脚杯螺母是否锁紧。

6: Check whether the foot cup is stable and balanced. Is the foot cup nut locked tight.

七：定期检查各个可见螺丝是否松动，电机联轴器螺丝紧固，同步轮螺丝紧固。

7: Check regularly whether each visible screw is loose, the motor coupling screw is tightened, and the synchronous wheel screw is tightened.

八：定期检查各电器部件插头是否松动。

8: Regularly check whether the plug of each electrical component is loose.

九：定期用酒精布擦拭台面，保持台面干净。

9: Regularly wipe the table with alcohol cloth to keep the table clean.

十：移动设备推机架部分，不要手推平台和拉料辊筒。需推机架部位。

10: Move the equipment to push the rack part, do not hand push the platform and pull the material roller. Need to push the rack parts.

设备安装尺寸图

Equipment installation size drawing

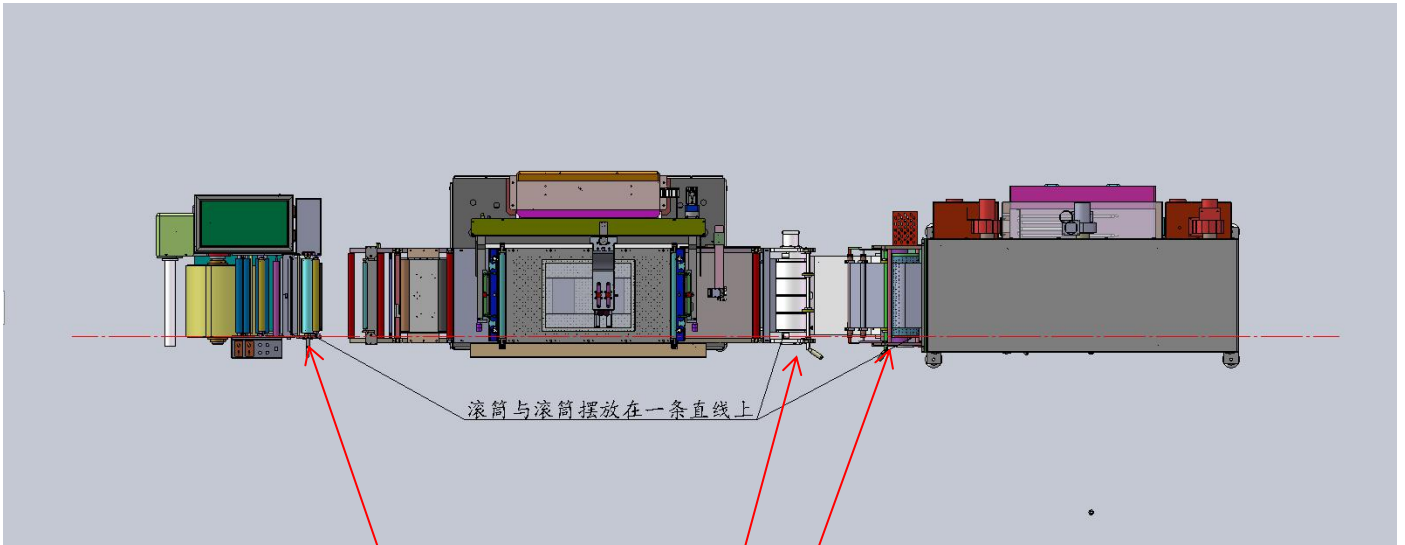
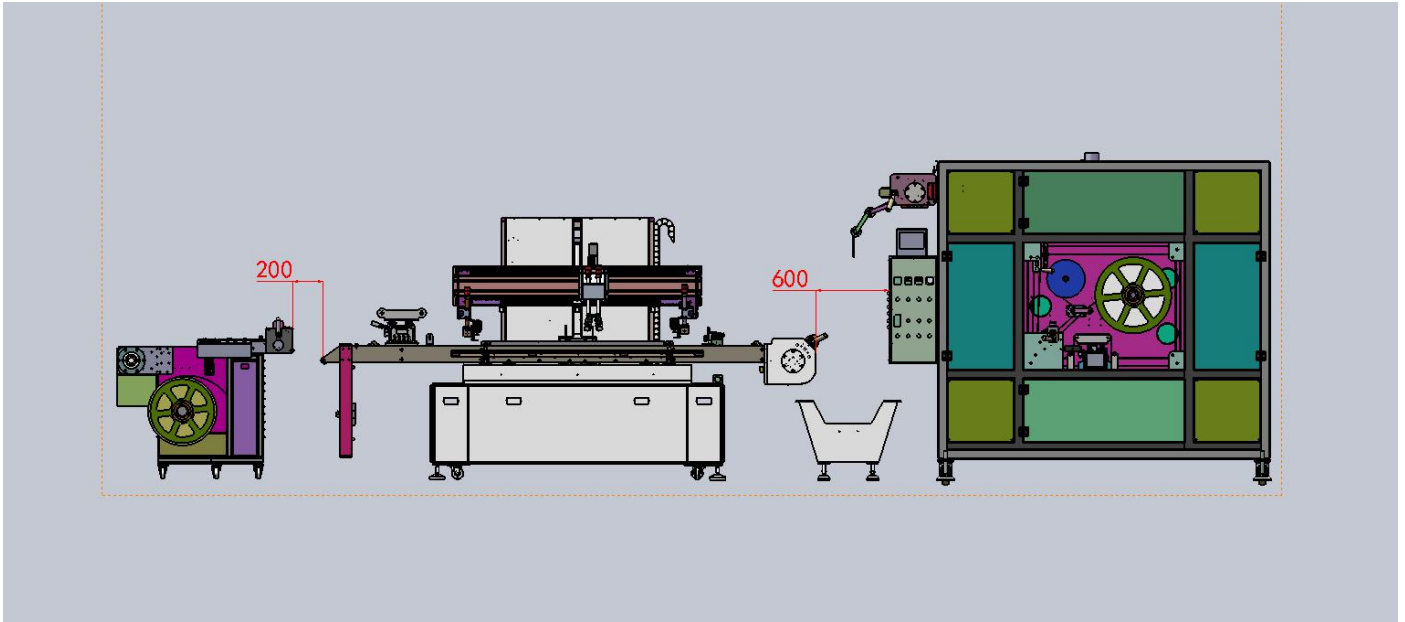

The rollers are arranged in a straight line with each other

电路安装图

Circuit installation diagram

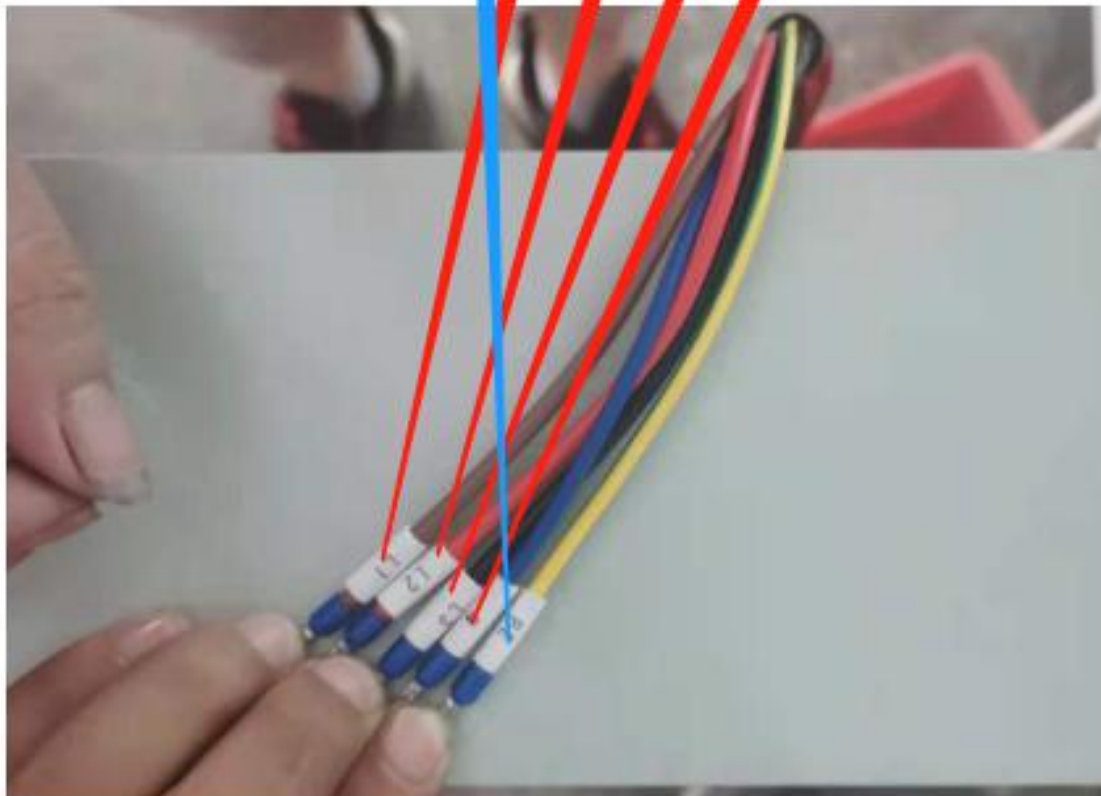

如果风机反转，请将 L1 和 L2 对换
If the fan reverses, please swap L1 and L2

气源安装

Air supply installation

